



SATURN GEO X





Order Codes

Order No.

SATURN GEO X

SATURN GEO X BASIC SET

Incl.2 safety measuring leads with test tips and crocodile clips,
6 batteries, carrying strap, manual.

A188506510

SATURN GEO X with INTERFACE and GEO-MEASURING-SET 4pole

Incl.2 safety measuring leads with test tips and crocodile clips,
4 earth stakes,3 reels with 2x25m and 1x50 m wire,
Interface, Set-up Software, RS232 cable & PC adapter,6 batteries,
carrying strap and manual in carrying case.

A188506512

SATURN GEO X with GEO-MEASURING-SET 4pole in carrying case UNIVERSAL

Incl.2 safety measuring leads with test tips and crocodile clips,
4 earth stakes, 3 reels with 2x25m and 1x50 m wire, 6 batteries,
carrying strap and manual in carrying case UNIVERSAL (ST0010Z).

A188506513

Accessories:

GEO-CLAMP SET SELECTIVE

includes:

1 current clamp 100A

1 cable for clamp connection.

A 6045 10305

GEO-CLAMP SET STAKELESS

includes:

1 current clamp 100A

1 current clamp 1000A

1 cable for clamp connection

1 adapter for stakeless measurement + manual

A 6045 10306

REEL with 25 m wire

REEL with 50 m wire

A 6045 05102

A 6045 05103

Split-core current transformer

for measurements on high voltage pylons \varnothing 310 mm

A 6805 06211

Accuset 600 mAh

with NiCad-batteries and quick charge unit

A 6403 06211

Contents

1	SAFETY INSTRUCTIONS	2
2	FIRST SETUP	3
3	GENERAL	4
4	ASSEMBLY	6
5	DESCRIPTION OF FUNCTIONS	7
6	TECHNICAL DATA	9
7	DESCRIPTION OF THE OPERATING ELEMENTS	19
8	PROCEDURE OF MEASUREMENTS	22
8.1	General	22
8.2	Measurement of interference- voltages and frequencies	28
8.3	Measurement of earthing resistances	29
8.4	Measurement of single earth electrode resistances in mesh operated earthing systems	32
8.5	Measurement of soil resistivity	41
8.6	Measurement of resistances	43
8.7	Changing of all data settings with personalized CODE	46
9	DESCRIPTION OF DISPLAYS	49
10	CARE AND MAINTENANCE	53
10.1	Recharging NiCad batteries	53
10.2	Replacing batteries	53
10.3	Recalibration	54
10.4	Storage	54
11	SERVICE	55
11.1	WARRANTY	55
12	Basic APPENDIX	56
12.1	Earthing resistance	56
12.2	Soil resistivity ρ_E	57
12.3	Measuring method	59
12.4	The potential gradient area	60
12.5	The influence of potential gradient areas on earth resistance measurement	61
12.6	Earth impedance (R^*) on high voltage transmission lines	62

1 SAFETY INSTRUCTIONS



This measuring equipment is only to be operated by **qualified staff** and in accord with its technical data in compliance with the safety precautions and instructions set forth below. In addition, use of this equipment requires compliance with the legal and safety instructions pertaining to the specific application in question. Similar precautions apply to the use of accessories.



CAUTION: Operation of electrical equipment inevitably causes certain parts of such equipment to carry dangerous voltage. Non-compliance with precautions may therefore cause major physical or material damage.

Fault-free and reliable operation of this instrument requires suitable transport and storage, setting-up and assembly, as well as care in operation and maintenance.

If there is reason to believe that risk-free operation is no longer possible, the instrument should be switched off immediately and protected against accidental restarting. Risk-free operation shall be deemed to be no longer possible if and when the instrument

- shows visible damage,
- fails to work in spite of functioning batteries,
- has been exposed for some time to unfavorable conditions (e.g. storage beyond the permissible climatic limits without adaptation to the ambient climate, dewing etc.),
- has been exposed to major strain during transport (e.g. been dropped from some height without visible external damage etc.), or
- shows " E1 ... E5 " on the display.

Qualified Staff

consists of persons familiar with the setting up, assembly, starting up and operation of the product and possess the qualifications required for such activities, such as

- training, instruction and/or authorization to perform the following operations on circuits and equipment according to safety engineering standards: switching on and off, disconnecting, earthing/grounding, labeling;
- training or instructions according to safety engineering standards in the care and maintenance of adequate safety equipment.
- training in rendering first aid.

2 FIRST SETUP

Unpacking

When unpacking the instrument watch out for possible damages that may have occurred during transport. In the case of defects the packing material must be kept until the complaint is adjusted.

Keep the packing material also in case you need it to transport the instrument at a later date.

Checking the scope of delivery

Upon unpacking immediately check the accessories for missing parts. The accessories supplied are listed on page 2.

Although the instrument is easy to operate please read these operating instructions carefully for safety reasons and in order to make optimum use of the instrument.

How to fasten the carrying strap

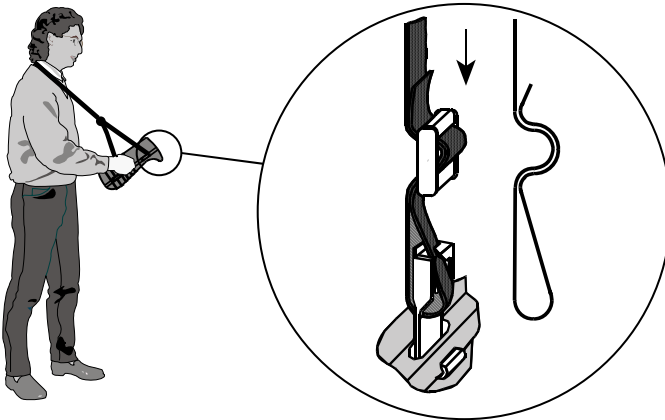

This test instrument is equipped with a mains power supply.

The measuring functions are only all activated when the instrument is connected.

3 GENERAL

Microprocessor controlled universal earth resistance meter with fully automated measuring frequency selection process as well as automatic testing of probe- and auxiliary earth electrode resistances and possible interference voltages as per DIN IEC61557-5/EN61557-5.

- Measurement of interference voltage (U_{ST})
- Measurement of interference frequency (F_{ST})
- Measurement of probe resistance (R_S)
- Measurement of auxiliary earth electrode resistance (R_H)
- Measurement of earthing resistance 3pole, 4pole, (R_E)
with or without using the external clip-on current transformer for selective measurement of single earthing branches in mesh operated earthing systems ()
- Resistance measurement 2pole with AC voltage (R_{\sim})
- Resistance measurement with DC voltage 2pole, 4pole, (R_{DC})
- Optional interface (RS 232)

With its various possibilities of measurement and the fully automated measuring sequence control (incl. automatic frequency control AFC), this instrument offers the latest measuring technology in the field of earthing resistance measurements. By means of the selectable limit input with visual and accoustical confirmation/error message and with the code programmable and customer defined special functions, e.g. measuring voltage 20 V (for agricultural systems), earthing impedance R^* (measuring frequency 55Hz) switched on or off etc., these instruments are individually programmable for use as a simple meter as well as a high end fully automated measuring device.

The instrument can be upgraded by using optional devices:

An **external current transformer** with a transformation ratio between 80 and 1200:1 for the measurement of a single branch in mesh operated earthing systems is available as an option and enables the user to measure on high voltage pylons without separating the overhead earth wires or earth strips at the bottom of the pylons and also to measure lightning protection systems without separating the individual lightning protection wires.

An **interface** for the output of measured values on a printer or to a memory pack or for data interchange with a personal computer, is available as an optional retrofit kit. A data output includes all values displayable (R_E , R_S , R_H , etc.) as well as date and time of measurement and a customer defined text.

A **NiCad battery pack** which can be recharged from mains or car battery .
An adaptor for spikeless earth measurement allows fast and simple measurement of "earth-loops"and testing of lightning protection systems without sonds and auxiliary earth.

4 ASSEMBLY

The instrument is made up of two parts:

- 1) The base part which contains the entire measuring electronics.
- 2) The protective housing with attachable carrying strap.

The functions are selected with the central rotary switch. Four rubber buttons, which start measurements, read out supplementary measuring values and select special functions, are located on the left hand side of the front panel. This design enables quick and clear one-hand operation.

The measured values are displayed on a liquid crystal display with correct decimal point and unit. Various additional special characters indicate measuring mode, operating condition and error messages.

The auxiliary power supply consists of 6 x 1,5 V batteries (IEC R6 or LR6) or NiCad battery pack (optional).

The measuring instrument is manufactured complying with IP 56 (splash water proof). Air and leakage paths are dimensioned according to IEC61010-1/EN61010-1. The instrument complies with protection class II (□).

This device has been developed, designed and manufactured in compliance with quality system DIN ISO 9001.

5 DESCRIPTION OF FUNCTIONS

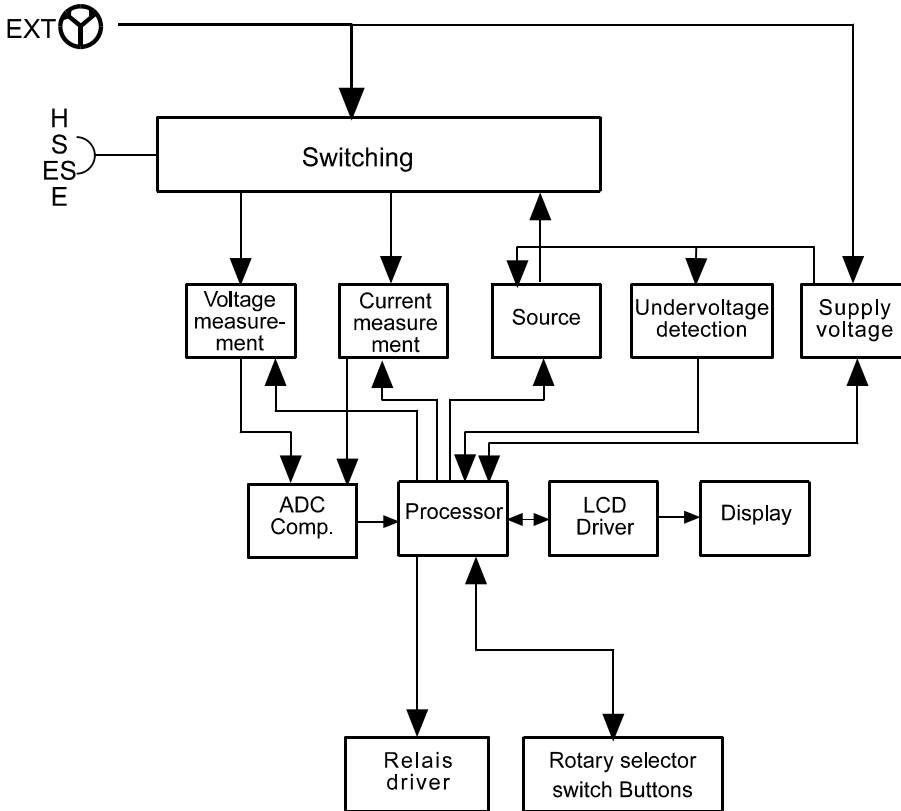

Measurement of interference voltage (U_{ST})

Fullwave rectification for DC and AC (DC without operational sign, AC signal sinus calibrated for r.m.s. values). If limit values are exceeded no measurement will be started.

Measurement of interference frequency (F_{ST})

For interference voltage $>1V$ its frequency is derived from the period time.

Measurement of earthing resistance (R_E)

The earthing resistance is determined by a 3- or 4-pole current and voltage measurement. The measuring voltage is a square pulse AC voltage with 48 / 20 V and a frequency of 94 , 105 , 111 or 128 Hz. The frequency can be selected manually or automatically (AFC) .

Selective measurement of earthing resistance* (R_E)

Measurement of a single earth electrode in a mesh operated (parallel) earthing system. The current flowing through the single earth electrode is measured with an external current transformer.

Resistance measurement (R_{\sim})

The resistance is determined by a 2 pole current and voltage measurement. The measuring voltage is a square pulse AC voltage with 20 V and a frequency of 94, 105, 111 or 128 Hz. The frequency can be selected manually or automatically (AFC).

Low resistance measurement (R_{∞})

The resistance is determined by DC current and voltage measurement. 2- as well as 4-pole measurement is possible. The short circuit current is > 200 mA. The resistance of both current directions is measured and stored.

Checking for correct measuring connection

Via split socket and following detection circuit, the processor checks if the measuring lead is properly connected according to the selected function. A wrong or missing connection is indicated by an optical or acoustical signal.

Beeper

The built in beeper has two functions:

1. Giving messages if set limit values are exceeded.
2. Indicating dangerous conditions or maloperation.

Controlling is done by means of the microprocessor.

LO-BAT

Supervision of the battery charge status is done with a comparator circuit. Via microprocessor, a drop in battery capacity down to typ. 10 % of its specified value is indicated on the display with symbol **LO-BAT** .

* Patent applied for.

6 TECHNICAL DATA

General:	Microprocessor controlled, fully automated earth measuring instrument with additional functions
Measuring function:	interference voltage and frequency, earthing resistance 3- and 4-pole with / without clip-on current transformer, resistance 2-pole with AC, 2- and 4-pole with DC
Display:	4 digit (2999 Digit) - 7 segment liquid crystal display, digit size 18 mm with supplementary signs and active illumination.

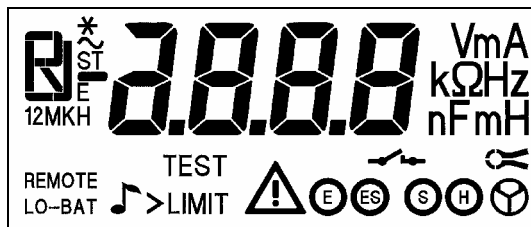







Operation:	Central rotary switch and function keys
Working temperature range:	-10 °C ... +50 °C
Operating temperature range:	0 °C ... +35 °C
Nominal temperature range:	18 °C ... +28 °C
Storage temperature range:	-30 °C ... +60 °C
Temperature coefficient:	± 0.1 % of range / Kelvin
Operating errors:	refer to operating temperature range and $R_H < 20 R_E$, $R_S < 100 R_E$

The maximum percentage operating error within the measurement range does not exceed ± 30 % with the measured value as fiducial value, as determined in accordance with table 6-1 on page 12.

The operating error applies under the rated operating conditions given in IEC1557-1 and the following:

- injection of series interference voltages with system frequencies of 400 Hz, 60 Hz, 50 Hz, 16 ²/₃ Hz or with d.c. voltage respectively across the terminals E (ES) and S. The r.m.s. value of the series interference voltage shall be 3 V;
- resistance of the auxiliary earth electrode and of the probes: 0 to 100 x R_A but ≤ 50 kΩ;

- system voltages between 85 % and 110 % of the nominal voltage and between 99 % and 101 % of the nominal system frequency for measuring equipment with a mains supply and/or measuring equipment deriving its output voltage directly from the distribution system.

Limits of error:	refer to nominal temperature range
Climate class:	JWE as per DIN 40040 (3 / 73) annual mean of relative humidity \leq 65 % , max 85 % , no dewing.
Type of protection:	IP 56 as per DIN 40050 (7/80)
Protection class:	Protection class II () as IEC61010-1/EN61010-1
Max voltage:	 socket  to socket     Urms = 0 V Sockets " E ES S H " to each other in any combination, max. Urms= 250 V
Safety standards:	IEC61010-1/EN61010-1 300 V CATIII IEC61557-1, -5/EN61557-1, -5
Electromagnetic compatibility:	
Emission:	Class B as per EN 50081-1/ IEC(EN) 61326-1: 1997
Immunity:	IEC61000-4-2 8 kV (air) B IEC61000-4-3 3 V/m A
Quality standard:	developed, designed and manufactured to comply with DIN ISO 9001
External field influence:	complies with DIN 43780 (8/76)
Auxiliary power:	6 x 1,5 V alkali-manganese-batteries (IEC LR6) or 1,2 V NiCad batteries (optional)
Battery life span:	with IEC LR6: typ. 3000 measurements ($R_E + R_H \leq 1 \text{ k}\Omega$) with NiCd batteries: typ. 1500 measurements ($R_E + R_H \leq 1 \text{ k}\Omega$) with IEC LR6 : typ. 6000 measurements ($R_E + R_H > 10 \text{ k}\Omega$) with NiCd batteries: typ. 3000 measurements ($R_E + R_H > 10 \text{ k}\Omega$)
Dimensions:	240 mm (Ω) x 220 mm (D) x 90 mm (H)
Weight:	\leq 1.1 kg without accessories \leq 5.5 kg incl. accessories and batteries in carrying case
Case material:	NORYL, shock -and scratch proof thermoplast

Measurement of interference voltage DC + AC (U_{ST})

Measuring method: fullwave rectification

Measuring range	Display range	Resolution	Frequency range	Limits of error
1...50 V	0.0...50 V	0.1 V	DC/AC 45...400 Hz sine	\pm (5% of mv +5 digit)

Measuring sequence: approx. 4 measurements /s

Internal resistance: approx. 1.5 M Ω

Max. overload: $U_{rms} = 250$ V

Measurement of interference frequency (F_{ST})

Measuring method: Measurement of oscillation period of the interference voltage

Measuring range	Display range	Resolution	Range	Limits of error
16.0 ... 400 Hz	16.0...299.9...999 Hz	0.1 ... 1Hz	1 V ... 50 V	\pm (1% v. mv +2 digit)

Earthing resistance (R_E)

Measuring method: current and voltage measurement with probe as IEC61557-5/EN61557-5
 Open circuit voltage: 20 / 48 V, AC
 Short circuit current: 250 mA AC
 Measuring frequency: 94 , 105 , 111 , 128 Hz selected manually or automatic.(AFC) 55 Hz in function R*
 Noise rejection: 120 dB (16^{2/3}, 50 , 60, 400 Hz)
 Max. overload: U_{rms} = 250 V

Intrinsic error or influence quantity	Reference conditions or specified operating range	Designation code	Requirements or test in accordance with the relevant parts of IEC 1557	Type of test
Intrinsic error	Reference conditions	A	Part 5, 6.1	R
Position	Reference position ± 90°	E1	Part 1, 4.2	R
Supply voltage	At the limits stated by the manufacturer	E2	Part 1, 4.2, 4.3	R
Temperature	0 °C and 35 °C	E3	Part 1, 4.2	T
Series interference voltage	See 4.2 and 4.3	E4	Part 5, 4.2, 4.3	T
Resistance of the probes and auxiliary earth electrodes	0 to 100 x R _A but ≤ 50 kΩ	E5	Part 5, 4.3	T
System frequency	99 % to 101 % of the nominal frequency	E7	Part 5, 4.3	T
System voltage	85 % to 110 % of the nominal voltage	E8	Part 5, 4.3	T
Operating error	$B = \pm(A + 1,15 \sqrt{E_1^2 + E_2^2 + E_3^2 + E_4^2 + E_5^2 + E_6^2 + E_7^2 + E_8^2})$		Part 5, 4.3	R
A = intrinsic error E _n = variations R = routine test T = type test		$B[\%] = \pm \frac{B}{\text{fiducial value}} \times 100\%$		

table 6-1

Measuring range	Display range	Resolution	intrinsic error	max. operating error
0.020 Ω... 300 kΩ	0.001 Ω...2.999 Ω	0.001 Ω	± (2 % of mv +2 digit)	± (5% of mv +5 digit)
	3.00 Ω...29.99 Ω	0.01 Ω		
	30.0 Ω...299.9 Ω	0.1 Ω		
	0.300 kΩ...2.999 kΩ	1 Ω		
	3.00 kΩ...29.99 kΩ	10 Ω		

30.0 kΩ...299.9 kΩ

100 Ω

Measuring time:

typ. 8 sec. with a fixed frequency

30 sec. max. with AFC and complete cycle of all measuring frequencies

Additional error because of probe- and auxiliary earth electrode resistance:

$$\frac{R_H(R_S + 2000\Omega)}{R_E} \times 1,25 \times 10^{-6} \% + 5 \text{ digits}$$

Measuring error of R_H and R_S :typ. 10% of $(R_E + R_S + R_H)$

Max. probe resistance:

 $\leq 1 \text{ M}\Omega$

Max. auxiliary earth electrode resistance:

 $\leq 1 \text{ M}\Omega$

Automatic check if error is kept within the limits required by IEC61557-5/EN61557-5:

If after a measurement of probe-, auxiliary earth electrode- and earthing resistance, a measurement error of higher than 30 % is assumed because of the influencing conditions (see diagram), the display shows a warning symbol  and a notice that R_S or R_H are too high.

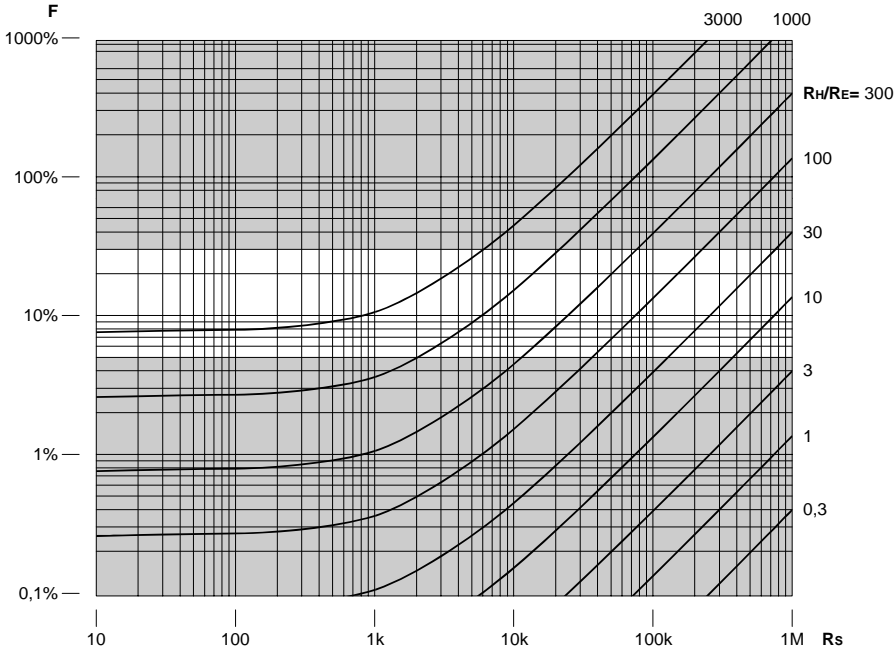

Automatic switchover of measuring resolution in dependence to auxiliary earth electrode resistance R_H :

R_H with $U_{meas} = 48\text{ V}$	R_H with $U_{meas} = 20\text{ V}$	Resolution
< 300 Ω	< 250 Ω	1 m Ω
< 6 k Ω	< 2,5 k Ω	10 m Ω
< 60 k Ω	< 25 k Ω	100 m Ω
< 600 k Ω	< 250 k Ω	1 Ω

Selective measurement of the earthing resistance (R_E)

Measuring method: current and voltage measurement with probe as per DIN VDE 0413 part 7 (7 / 82) and current measurement in the individual branch with additional current transformer (patent applied for).

Open circuit voltage: 20 / 48 V AC

Short circuit current: 250 mA AC

Measuring frequency: 94, 105, 111, 128 Hz selected manually or automatically (AFC), 55 Hz (R^*)

Noise rejection: 120 dB (16 $^{2/3}$, 50, 60, 400 Hz)

Max. overload: max. $U_{rms} = 250\text{ V}$ (measurement will not be started)

Measuring range	Display range	Resolution	intrinsic error *	Operating error *
0.020 Ω ... 30k Ω	0.001...2.999 Ω	0.001 Ω	\pm (7 % of m.v. +2 digit)	\pm (10% of m.v. +5 digit)
	3.00...29.99 Ω	0.01 Ω		
	30.0...299.9 Ω	0.1 Ω		
	0.300...2.999 k Ω	1 Ω		
	3.00...29.99 k Ω	10 Ω		

* With recommended current clamps / transformers.

Additional error because of probe- and auxiliary earth typ.electrode resistance:

$$\frac{R_H(R_S + 2000\Omega)}{R_{E\text{ TOTAL}}} \times 1,25 \times 10^{-6} \% + 5\text{ digits}$$

Measuring error of R_H and R_S :

typ.of 10% of ($R_{E\text{ TOTAL}} + R_S + R_H$)

Measuring time:

typ. 8 sec. with a fixed frequency

30 sec.max. with AFC and complete cycle of all measuring frequencies

Minimal current in single branch: 0.5 mA with transformer (1000 :1)
 to be measured: 0.1 mA with transformer (200 :1)

Max. interference current through transformer: 3A with a transformer (1000:1)

Resistance measurement (R_~)

Measuring method: current and voltage measurement
 Measuring voltage: 20 V AC, square pulse
 Short circuit current: > 250 mA AC
 Measuring frequency: 94 , 105 , 111 , 128 Hz selected manually or automatically (AFC)

Measuring range	Display range	Resolution	intrinsic error	Operating errors
0.020 Ω... 300 kΩ	0.001 Ω ... 2.999 Ω	0.001 Ω	± (2 % of m.v. +2 digit)	± (5% of m.v. +5 digit)
	3.0 Ω ... 29.99 Ω	0.01 Ω		
	30 Ω ... 299.9 Ω	0.1 Ω		
	300 Ω ... 2999 Ω	1 Ω		
	3.0 kΩ ... 29.99 kΩ	10 Ω		
	30.0 kΩ ... 299.9 kΩ	100 Ω		

Measuring time: typ. 6 sec.
 Max. interference voltage: 24 V, with higher voltages measurement will not be started
 Max overload: Urms max. = 250 V

Resistance measurement (R_≡)

Measuring method: current- voltage measurement as per IEC61557-4/EN61557-4 possible
 Open circuit voltage: 20 V DC
 Short circuit current: 200 mA DC
 Formation of measured value: with 4-pole measurement wires on H , S , ES can be extended without additional error.
 Resistances >1 W in wire E can cause additional error of 5m Ω/Ω.

Measuring range	Display range	Resolution	intrinsic error	Operating error
0.020 Ω... 3 kΩ	0.001 Ω ... 2.999 Ω	0.001 Ω	± (2 % of m.v. +2 digit)	±(5% of m.v. +5 digit)
	3.0 Ω ... 29.99 Ω	0.01 Ω		
	30.0 Ω ... 299.9 Ω	0.1 Ω		

	300 Ω ... 2999 Ω	1 Ω	
--	------------------	-----	--

Measuring sequence:	approx. 2 measurements/s
Measuring time:	typ. 4 sec. incl. reversal of polarity (2 pole or 4 pole)
Max. interference voltage:	≤ 3 V AC or DC, with higher voltages measurement will not be started
Max inductivity:	2 Henry
Max. overload:	Urms = 250 V

Compensation of lead resistance (R_K)

Compensation of lead resistance (R_K) can be switched on in functions RE 3pole , RE 4pole  , R~ , and R ≡ 2pole

Formation of measured value:

$R_{display} = R_{measured} - R_{compensated}^*$
 * Value of setpoint entry $R_K = 0.000$ W, variable from 0.000...29.99 W by means of measuring adjustment

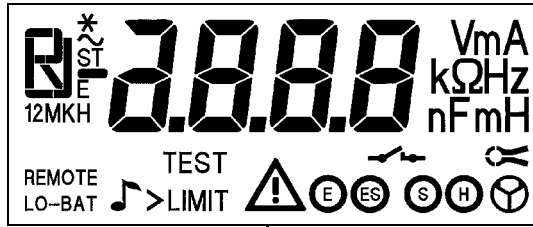

6

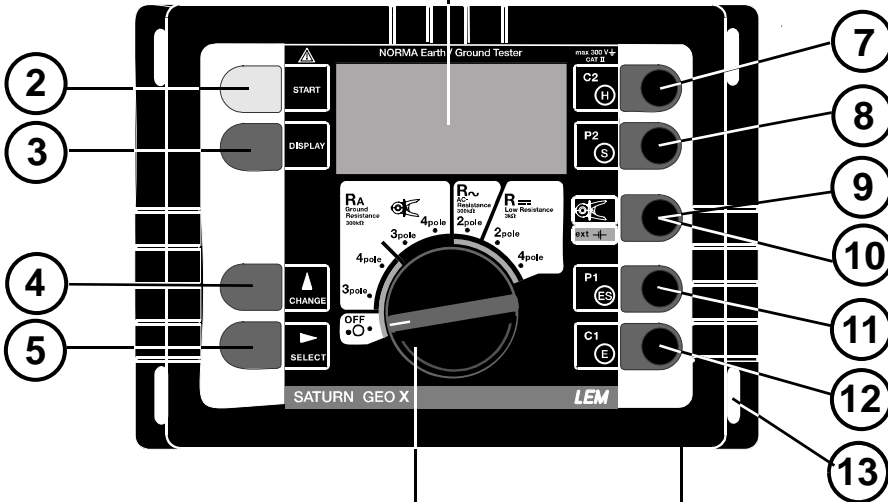

back / Rückseite / derrière

1

14

15

16

7 DESCRIPTION OF THE OPERATING ELEMENTS

- ① Central rotary switch to select measuring function or switch ON/OFF
- ② "START"-button to start the set measuring function.
- ③ "DISPLAY"-button to call corresponding supplementary values.
- ④ "CHANGE ▲" button to change the set point entry values
- ⑤ "SELECT ►" button to select the digit to be changed, printout (with Interface)
- ⑥ Display unit, liquid crystal digits, 18 mm high with automatic decimal point as well as active illumination.

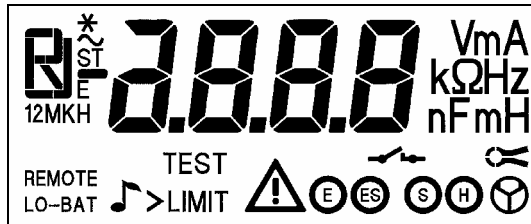

- ⑦ Connecting socket ^(H) (auxiliary earth electrode) (4 mm ø) also usable with safety measuring lead
- ⑧ Connecting socket ^(S) (probe) (4 mm ø) also usable with safety measuring lead.
- ⑨ + ⑩ Connecting socket for an ext. clip-on current transformer (optional), and for external charging of NiCad batteries, can not be attached simultaneously



WARNING: no voltage permissible to sockets „^(E)^(ES)^(S)^(H)“.

- ⑪ Connecting socket ^(ES) (earthing probe) (4 mm ø) also usable with safety measuring lead. Potential pick off with 4-pole earthing measurement.
- ⑫ Connecting socket ^(E) (earth electrode) (4 mm ø) also usable with safety measuring lead.
- ⑬ Carrying belt attachment.



ATTENTION: do not open or close the instrument with force!

- ⑭ Battery compartment for: 6 x IEC LR6 batteries or NiCad batteries.



WARNING: Disconnect all leads before opening the instrument!

- ⑮ Screws to fasten the battery compartment
- ⑯ Interface-connection serial port (optional)

Description of display elements

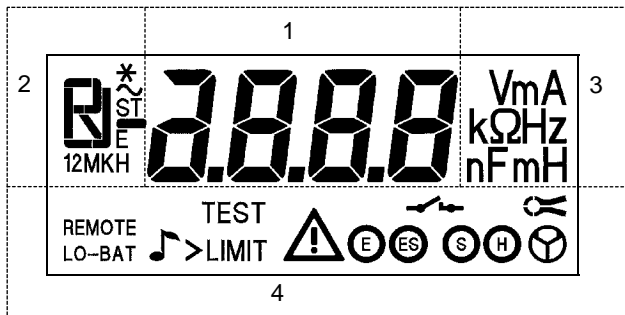

The display is divided into four display elements:

1. Digital display of measured value
2. Measuring function field to display measuring function
3. Unit field: V, Ω , k Ω , Hz
4. Special characters for operator guidance

Description of display symbols

UST	Interference voltage (AC + DC)
FST	Frequency of interference voltage
FM	Frequency of measuring voltage
UM	Measuring voltage limit 20/48 V
RE	Earthing resistance
RH	Auxiliary earth electrode resistance
RS	Probe resistance
RK	Compensation resistance
R ₁ , R ₂	Low voltage measurement with polarity indication
R _~	AC- resistance
R*	Earthing impedance (measuring frequency 55Hz)
AFC	Automatic-frequency-control
TEST	Measuring sequence in process
LIMIT	Limit value
> LIMIT	Limit value exceeded
(E) (ES) (S) (H)	Socket recognition
	Recognition of current transformer socket
	Message of an exceeded limit with beeper
LO-BAT	Battery voltage too low, replace batteries.

REMOTE



Interface (optional) active - button operation locked
Measuring circuit (E-S,E-H) interrupted or measured value
instable



WARNING: Refer to operating instructions

8 PROCEDURE OF MEASUREMENTS



WARNING: Use the instrument on voltage free systems only

Operation is easy :

Set measuring function with the central rotary switch ① !

Connect instrument ! without measuring lead connected **START** is omitted !

Start measurement with "START" button ② .

read out measured value.

For optimum performance and utilization of the device observe the following points:

8.1 General

8.1.1 POWER ON Functions

During switching on of the instrument with the central rotary switch it is possible to access certain operating conditions by pressing certain button combinations:

a) Standard mode

If the device is put into operation without further button control, it switches into a battery saving condition (Stand by-display "---") approx. 50 seconds after the termination of a measurement, or after a button push or turn of the rotary switch. Pressing the "display button" reactivates the instrument; the "old" measured values can be read out again. After 50 min. of stand by the Display is turned off completely. Instrument is reactivated with ON / OFF on the rotary switch

b) Stand by disable

A simultaneous push of buttons "DISPLAY" and "CHANGE ▲" during switching on prevents the instrument from being switched off automatically (Stand by). The battery saving mode is reactivated with ON / OFF on the central rotary switch.

c) Prolonged displaytest

By keeping the "DISPLAY" button pressed during switching on, the display test can be prolonged for any length of time. Return to the standard operation mode by pressing any button or turning of the central rotary switch.

d) Number of software version

By keeping the "SELECT ►" button pressed during the switch on sequence, the number of the software version is indicated on the display. By pressing the "DISPLAY" button a switch over to the last calibration date is possible. This display sequence is terminated by turning the central rotary switch or pressing the "START" button.

Display format: SOFTWARE-version: X . X X
Date of calibration: M M . J J

Note: At delivery the date of calibration is set to 0.00. Only after the first recalibration a proper date is indicated.

e) Activation of display illumination

By keeping the "CHANGE ▲" button pressed during the switch on sequence the display illumination is activated. Illumination fades away automatically if the instrument is switched to "Stand by" and, together with the instrument, is switched on again by pressing any button. The instrument is switched off with ON/OFF on the central rotary switch exclusively.

8.1.2 Operation

The measuring functions have two initial operational modes:
The Control loop and the Measuring loop

Operation flow chart :

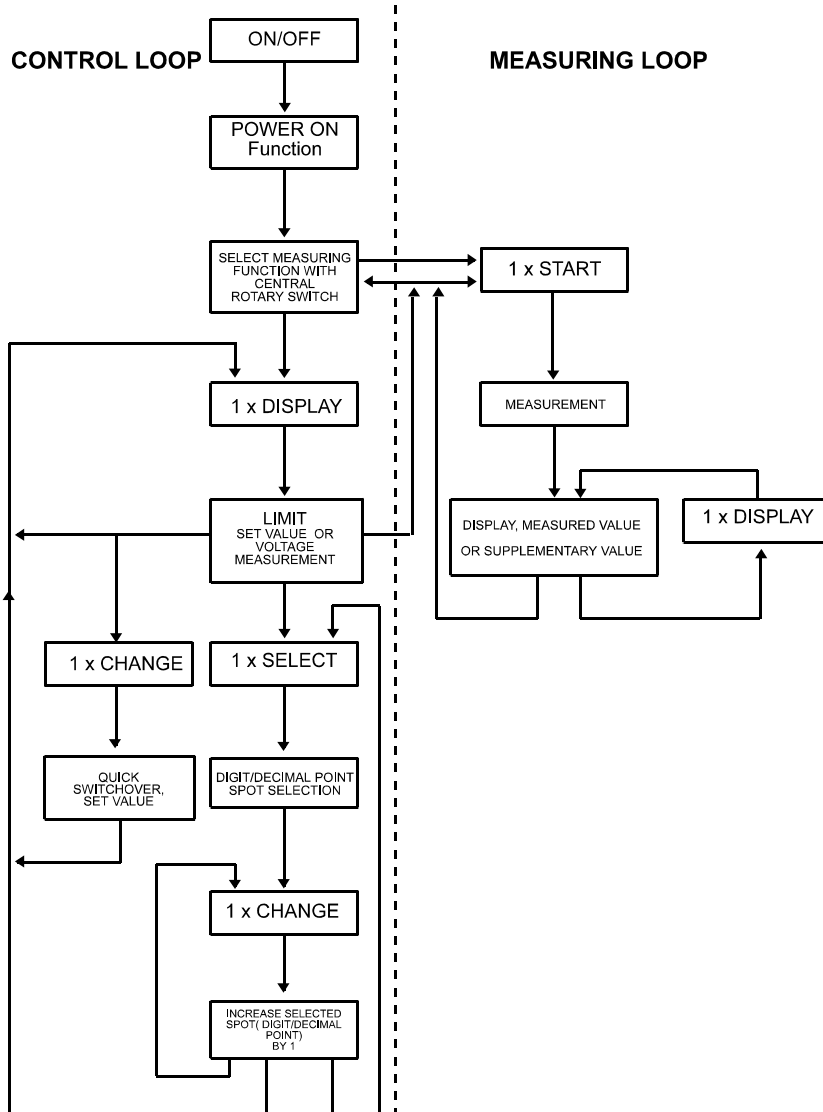



Control loop:

After turning the function rotary switch, the voltage display mode is reached. Pushing "DISPLAY" now calls up the control loop. According to the selected measuring function, different setting values can be displayed and changed in the control loop. The "DISPLAY" button switches between the different set values inside a continuous loop. The "SELECT ►" button selects the decimal point to be changed. Pushing the "CHANGE ▲" button the instrument either switches between certain set values or increases the decimal point selected with "SELECT ►" by 1.

After parameter setting has been finished the next display can be called with "DISPLAY" or the measurement can be started with "START" .

Depending on the selected function, the following parameters can be displayed or changed:

Function	Parameter	Setting range	Remarks
RE 3pole and RE 4pole	U _{ST}		display only
	F _{ST}		display only
	F _M	(AFC/94/105/111/128)Hz	
	U _M	48 V/20 V	lockable to 20 V with CODE
	R _K	0.000 Ω ... 29.99 Ω	in position RE 3pole only *
	RE LIMIT	0.000 Ω ... 999 kΩ	only if activated with CODE
RE 3pole  and RE 4pole 	♫ (warning-sound)	On/Off	only if RE LIMIT is activated with CODE
	R*	On/Off	only if activated with CODE
	U _{ST}		display only
	F _{ST}		display only
	F _M	(AFC/94/105/111/128)Hz	
	U _M	48 V/20 V	lockable to 20 V with CODE
	R _K	0.000 Ω ... 29.99 Ω	in position RE 3pole only *
	I (ratio)	80 ... 1200	display only
	RE LIMIT	0.000 Ω ... 999 kΩ	only if activated with CODE
♫ (warning-sound)	On / Off	only if RE LIMIT is activated with CODE	
R*	On / Off	only if activated with CODE	

* (see chapter 8.4.4)

Function	Parameter	Setting range	Remarks
R~	U _{ST}		display only
	F _{ST}		display only
	F _M	(AFC/94/105/111/128)Hz	
	R _K	0.000 Ω ... 29.99 Ω	
	R ~ LIMIT	0.000 Ω ... 999 kΩ	only if activated with CODE
	♪ (warning-sound)	On / Off	only if R ~ LIMIT is activated with CODE
R∴ 2pole and 4pole	U _{ST}		display only
	F _{ST}		display only
	R _K	0.000 Ω ... 29.99 Ω	
	R LIMIT	0.000 Ω ... 9,99 kΩ	only if activated with CODE
	♪ (warning-sound)	On / Off	only if R LIMIT is activated with CODE

Measuring loop:

This loop is entered by pressing the "START" button. After releasing "START" the last measured value stays on the display. By repeated pressing of the "DISPLAY" button all supplementary values can be called. If a measured value exceeds or falls below the pre-set limit, the limit can be displayed as well (with "DISPLAY"). In that case the measured value is displayed with a flashing "LIMIT" whereas the limit value is displayed with a steady "LIMIT"-symbol.

Inside the measuring loop parameters cannot be changed.

Further possibilities of button operation:

Warning sound (♪): cancel with "DISPLAY" (with display switchover) or with "CHANGE ▲" or "SELECT ►" button (without display switchover).

8.1.3 Checking of correct measuring connection (socket allocation)

The instrument implements an automatic check, corresponding to the measurement selected, to see if the correct input sockets are used.

The display symbols E ES S H and V and are assigned to the corresponding sockets.

From the way the symbols are displayed, the correctness of the connected wiring can be concluded by the following features:

- socket incorrectly wired (or, by mistake, not wired): corresponding symbol flashes.
- socket correctly wired: corresponding symbol is steady active
- socket correctly not wired: corresponding symbol is blank

8.1.4 Safety control measurements

Before each measurement the instrument automatically checks the measuring conditions and, while simultaneously displaying the kind of error, prevents measurements from being started under the following conditions:

- excessive voltage on the sockets ($> 24 \text{ V}$ in RE und R~; $> 3 \text{ V}$ in R $\overline{\text{---}}$)
- wrong or incomplete connection
- Problems during the measuring sequence (display " E1 ... E5") see display description chapter 8.
- Battery voltage too low (display LO-BAT)

8.2 Measurement of interference- voltages and frequencies

This measuring function detects possible interference voltages and their frequencies. This function is automatically active in every switch position before an earthing or resistance measurement. If the pre-set limit values are exceeded, the interference voltage is indicated as to high and a measurement automatically prevented. The frequency of an interference voltage is only measurable if the level of this interference voltage is higher than 1 V.

Bring central rotary switch in desired position, read out measured value of interference voltage, measured value of interference frequency is displayed with "DISPLAY"

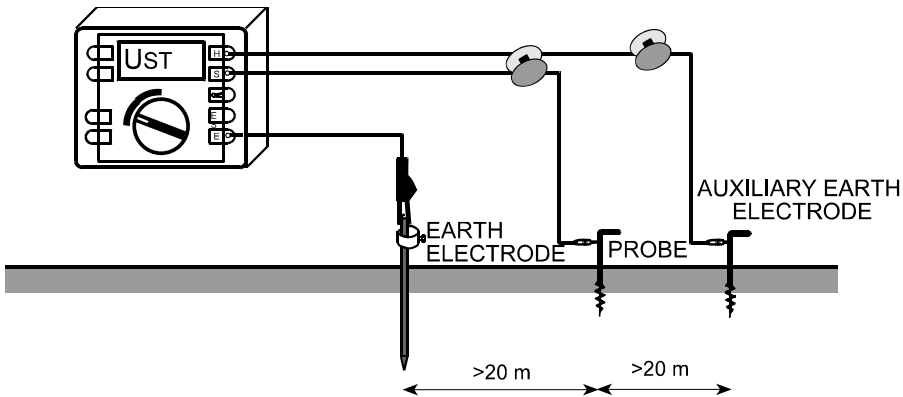

8.3 Measurement of earthing resistances

This instrument is equipped with a 3 pole as well as a 4 pole resistance measurement which renders measurements of resistances of earthing systems possible, as well as measurements of the soil resistivity of geological strata. A specific description of the different applications is given further on in this manual. As a special function, the instrument offers measurements with an external current transformer, with which a measurement of single resistance branches in interlinked networks (lightning protection and high voltage pylons with cabling) can be performed without separating parts of the system.

To ensure most feasible interference suppression during measurements, the instrument is equipped with 4 measuring frequencies (94 Hz, 105 Hz, 111 Hz, 128 Hz), with automatic switch over if necessary (AFC - Automatic Frequency Control). The corresponding measuring frequency used for a specific measurement can be called and displayed with "DISPLAY" after the measurement. Additionally, one of the four measuring frequencies can be selected and permanently set in special cases. In that case, in order to stabilize the display, an average measurement can be carried out for up to 1 minute by keeping the "START" button pressed.

To determine the earthing impedance (R^*) a measurement with a frequency close to the mains frequency (55 Hz) is carried out. At the activation of R^* through user's code, this measuring frequency is activated automatically.

To keep the instrument as simple as possible at the time of delivery and during a first encounter, all special functions, such as LIMIT input, BEEPER programming, measurement of earthing impedance (R^*) etc, are not activated at delivery. They can be activated with personalized user's code (see 8.7 "Changing of all Pre-set Data with Personalized Code").

Measuring method:

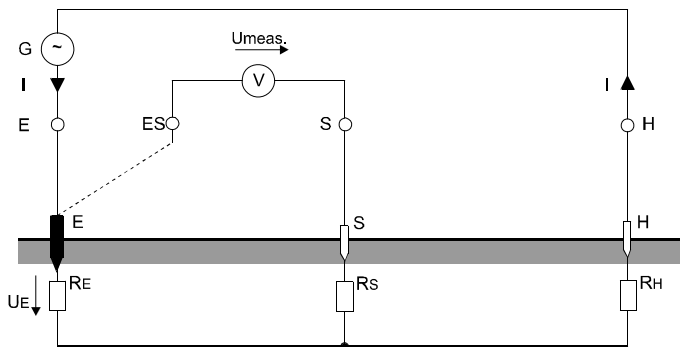

8.3.1 3-pole/4-pole measurement of earthing resistance

This measuring function measures earthing and earth dissipation resistances of single earth electrodes, foundation earth electrodes and other earthing systems by using 2 earth spikes.

Measuring process:

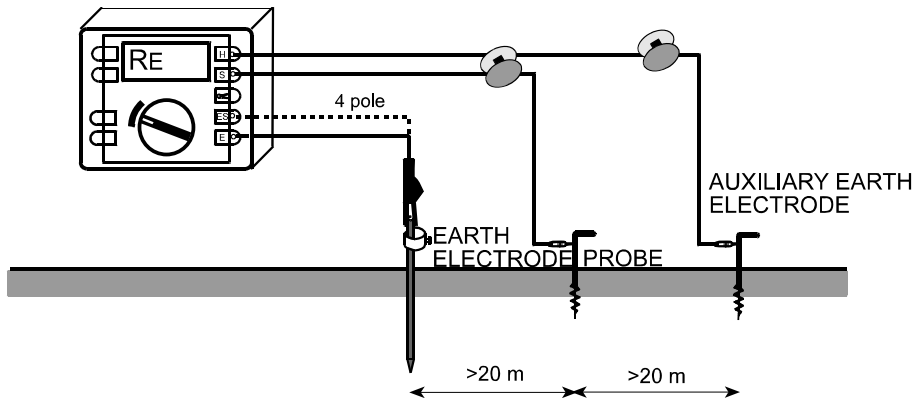

Turn central rotary switch to position " R_E 3pole" or " R_E 4pole"

The instrument is to be wired according to picture and notices given on the display.

A flashing of the sockets symbols E ES S H or K , points to an incorrect or incomplete connection of the measuring lead.

Press "START" button

Now a fully automated test sequence of all relevant parameters like auxiliary earth electrode, probe- and earth electrode resistance, is implemented and finished with the display of the result R_E .

Read out measured value R_E

Call R_S and R_H with "DISPLAY" .

Remarks for the setting of earth spikes:

Before setting the earth spikes for probe and auxiliary earth electrode make sure that the probe is set outside the potential gradient area of earth electrode and auxiliary earth electrode (also see 12.5). Such a condition is normally reached by allowing a distance of $>20\text{m}$ between the earth electrode and the earth spikes as well as of the earth spikes to each other.

An accuracy test of the results is made with another measurement following repositioning of the auxiliary earth electrode or probe. If the value stays the same, the distance is sufficient. If the measured value changes, probe or auxiliary earth electrode must be repositioned until the measured value R_E stays constant. Spike wires should not run too close.

3-pole measurement with longer earth electrode connecting leads

Use one of the supplied cable drums as earth electrode connecting lead. Spool off cable completely and compensate line resistance as described in 8.4.4,

Time average measurement:

If there is a warning "measured value unstable" (see 8. "Description of display") after a test sequence, most likely it is caused by strong interference signals (e.g. unsteady noise voltage). Nevertheless, to get reliable values, the instrument offers the possibility of averaging over a longer period.

Select a fixed frequency (see 8.1.2 "Control loop")

Keep the " START " button pressed until the warning " measured value unstable" disappears. Max. averaging time is approx. 1 min.

Evaluation of measured value:

The diagram shows the maximum permissible value of the Earth resistance which will not exceed a permissible limit value, taking into account the maximum usage error.

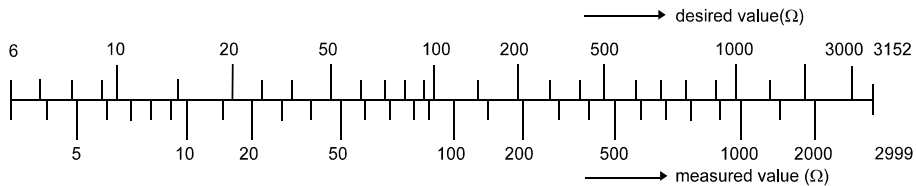

8.4 Measurement of single earth electrode resistances in mesh operated earthing systems

This patent pending measuring method has been created to measure single earth electrodes in permanently wired or mesh operated systems (e.g. lightning protection system with several electrodes or high voltage pylons with earth cabling etc.). By measuring the actual current flow through the earth electrode, this special measuring method provides the unique possibility to measure selectively only this particular resistance by means of a clip-on transformer (accessory). Other parallel resistances applied are not taken into account and do not distort the measuring result.

A disconnection of the earth electrode before the measurement is therefore no longer necessary !

Block diagram:

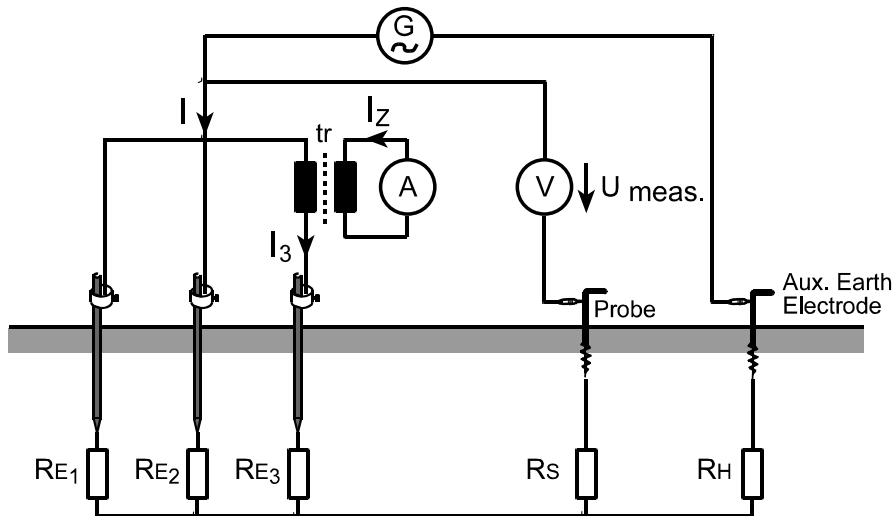

$$R_{E3} = \frac{U_{\text{meas.}}}{I_3} = \frac{U_{\text{meas.}}}{\text{tr} \cdot I_z}$$

Errors of the current transformer can be corrected as described in 8.4.3.

8.4.1 3-pole/4-pole measurement of single earth electrode resistances

Measuring process:

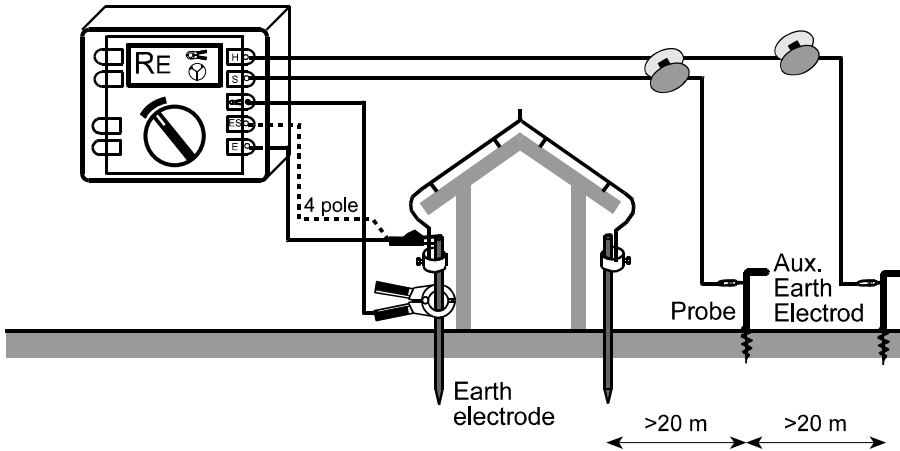

Turn central rotary switch to position " RE 3pole " or " RE 4pole ".

The instrument is to be wired according to picture and notices given on the display.

A flashing of the sockets symbols E ES S H or RE , points to an incorrect or incomplete connection of the measuring lead.

Fix clip-on transformer around the earth electrode to be measured.

Make sure that the clip-on transformation ratio set on the instrument corresponds to the

clip-on transformer used. Change settings if necessary (see 8.7)

Press "START" button.

Now a fully automated test sequence of all relevant parameters like auxiliary earth electrode, probe- and earth electrode resistance, is implemented and finished with the display of the result R_E .

Read out measured value R_E

Call R_S and R_H with "DISPLAY".

Remarks for the setting of earth spikes:

Before setting the earth spikes for probe and auxiliary earth electrode make sure that the probe is set outside the potential gradient of earth electrode and auxiliary earth electrode (see also 12.5). Such a condition is normally reached by allowing a distance of >20m between the earth electrode and the earth spikes as well as to the earth spikes to each other. An accuracy test of the results is made by another measurement following repositioning of the auxiliary earth electrode or probe. If the value stays the same, the distance is sufficient. If the measured value changes, probe or auxiliary earth electrode must be repositioned until the measured value R_E stays constant.

Spikes wires should not run too close.

3-pole measurement with longer earth electrode connecting leads

Use one of the supplied cable drums as earth electrode connecting lead.

Spool off cable completely and compensate line resistance as described in 8.4.4,

Time average measurement:

If there is a warning "measured value unstable" (see 8. description of displays) after a test sequence, most likely it is caused by strong interference signals (e.g. unsteady noise voltage). Nevertheless, to get reliable values, the instrument offers the possibility of averaging over a longer period.

Select a fixed frequency (see 8.1.2 "Control loop")

Keep the " START " button pressed until the warning " measured value unstable" disappears. Max. averaging time is approx. 1 min.

8.4.2 Measurements on high voltage pylons

8.4.2.1 Measuring the earthing resistance without disengaging the overhead earth wire

The measurement of the earth resistance of a single high voltage pylon usually requires the overhead earth wire to be disengaged (lifted off) or the separation of the earthing system from the pylon construction. Otherwise false reading of the resistance of the pylon earth electrode are liable to occur because of the parallel circuit of the other pylons connected to each other by an overhead earth wire.

The new measuring method employed in this instrument - with its external current transformer to measure the true current flowing through the earth electrode - allows measurements of earth electrode resistances without disconnection of the earthing system or disengaging the overhead earth wire.

As all four pylon stubs are connected to the foundation earth of the pylon, the measuring current I_{meas} is divided into five components according to the present resistances involved.

One part flows via pylon construction to the overhead earth wire and further to the parallelly circuited pylon earthing resistances.

The other four current components ($I_1 \dots I_4$) flow via the individual pylon feet.

The addition of all currents result in a current I_E going through the earthing resistance, i.e. the resistance of the "composite" earth electrode to the soil.

If the current transformer is fixed to each pylon stub, one after the other, four resistances have to be measured which show a behaviour inversely proportional to the corresponding current components $I_1 \dots I_4$. The feeding point of the measuring current is to be left unchanged to avoid a change in the current distribution.

Accordingly, these equivalent resistances are displayed as :

$$R_{Ei} = \frac{U_{meas.}}{I_i}$$

Therefore the earthing resistance R_E of the pylon is determined as a parallel circuit of the individual equivalent resistances :

$$R_E = \frac{1}{\frac{1}{R_{E1}} + \frac{1}{R_{E2}} + \frac{1}{R_{E3}} + \frac{1}{R_{E4}}}$$

Measuring process:

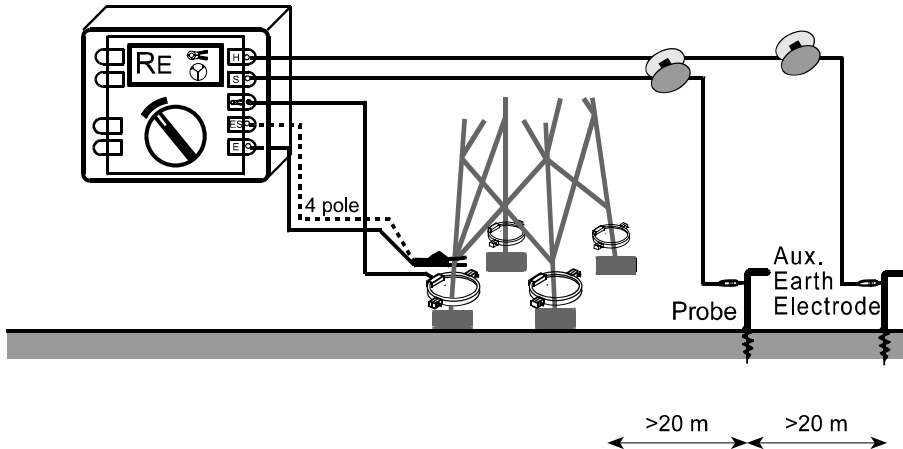

Turn central rotary switch to position "RE 3pole" or "RE 4pole"
The instrument is to be wired according to picture and notices given on the display.

A flashing of the sockets symbols $\text{E} \text{ ES } \text{S} \text{ H}$ or E , points to an incorrect or incomplete connection of the measuring lead.

Apply current transformer to the pylon stub. Make sure that the transformation ratio set on the instrument corresponds to the current transformer used. Change settings if necessary (see 8.7)

Press "START" button

Now a fully automated test sequence of all relevant parameters like auxiliary earth electrode, probe- and earth electrode resistance, is implemented and finishes with the display of the result R_E .

Read out measured value R_E

Call R_S and R_H with "DISPLAY" .

Notices for the setting of earth spikes:

Before setting the earth spikes for probe and auxiliary earth electrode make sure that the probe is set outside the potential gradient of earth electrode and auxiliary earth electrode (see also 12.5). Such a condition is normally reached by allowing a distance of >20m between the earth electrode and the earth spikes as well as to the earth spikes to each other. An accuracy test of the results is made with another measurement after repositioning of auxiliary earth electrode or probe. If the result is the same, the distance is sufficient. If the measured value changes, probe or auxiliary earth electrode must be repositioned until the measured value R_E remains constant. Spike wires should not run too close.

Apply current transformer to next pylon stub.

Repeat measuring sequence.

Current feeding point of measuring current (alligator clip) and the polarity of the split core current transformer has to be left unchanged.

After values of R_{Ei} of all pylon foots are determined, the actual earth resistance R_E has to be calculated :

$$R_E = \frac{1}{\frac{1}{R_{E1}} + \frac{1}{R_{E2}} + \frac{1}{R_{E3}} + \frac{1}{R_{E4}}}$$

Note:

If the displayed R_E value is negative despite correct orientation of the current transformer, a part of the measuring current is flowing upwards into the tower body. The earthing resistance, thus coming into effect, correctly calculates, if the individual equivalent resistances (under observation of their polarity) are inserted into the equation above.

Time average measurement:

If there is a warning "measured value unstable" (see 8. "Description of displays") after a test sequence, most likely it is caused by strong interference signals (e.g. unsteady noise voltage).

Nevertheless, to get reliable values, the instrument offers the possibility of averaging over a longer period.

Select a fixed frequency (see 8.1.2 "Control loop")

Keep the "START" button pressed until the warning "measured value unstable" disappears. Max. averaging time is approx. 1. min.

8.4.2.2 Measuring earthing impedance with 55Hz (R*)

For the calculation of short circuit currents in power supply plants, the complex earthing impedance is important. Direct measurement is possible under the following conditions:

Phase angle at 50 Hz:	30°... 60° inductive
auxiliary earth electrode (ohmic) :	> 100 · Z_E

Measuring process:

The measurement of the earthing impedance (R^*) is only possible if it is activated by putting in a personalized user's code (see 8.7 "change of setup data with personalized code"). If this measuring function is activated, in every measurement of the four R_E positions, the earthing impedance R^* is displayed before all other measured values.

8.4.3 Correcting clip-on transformer errors

If the measurement of an earthing resistance by means of a clip-on transformer results in a significantly different value as if measured without the clip-on, the deviation may be due to the tolerances of the clip-on current transformer. This error can be corrected by fine tuning the clip-on transformation ratio (basic settings 1000:1). This correction applies to the transformer current range it was performed with. For other ranges a different correction may be necessary.

Measuring process

Connect a low Ohm resistor (approx. 1 Ohm - in the range you want to correct) as described in the picture below.

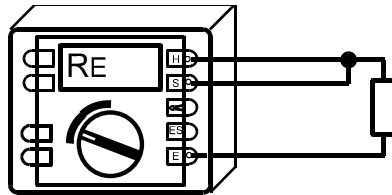

Turn central rotary switch to position " RE 3pole "
Press "START"-button and note result of R_E value.
Connect clip-on transformer

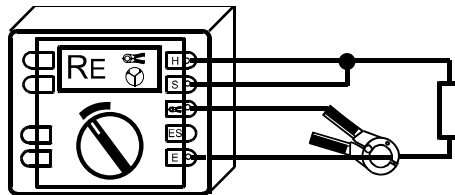

Turn central rotary switch to position " RE 3pole "
Press "START" again

If the thus measured value R_E deviates from the R_E value determined without clip-on transformer by more than 5%, adjust the clip-on transformation ratio (tr) correspondingly:

$$tr_{\text{new}} = tr_{\text{old}} \times \frac{R_E(\text{with clip-on transformer})}{R_E(\text{without clip-on transformer})}$$

Example:

Your clip-on transformer has a transformation ratio of $tr = 1000:1$. The measurement without clip-on transformer results in a value $R_E = 0,983 \Omega$. With a clip-on transformer a value of $R_E = 1.175 \Omega$ is measured. The deviation thus reads $(1.175 - 0.983) \Omega = + 0.192 \Omega$ and referring to $R_E = 0.983 \Omega$ an error evolves as following :

$$100\% \times \frac{0.192\Omega}{0.983\Omega} = +19.5\%$$

The new transformation ratio to be set calculates :

$$tr_{\text{new}} = 1000 \times \frac{1.175}{0.983} = 1195$$

8.4.4 Compensation of earth electrode connecting lead

If the line resistance to the earth electrode can not be ignored, a compensation of the connecting lead resistance to the earth electrode is possible. Proceed as described below:

Measuring process:

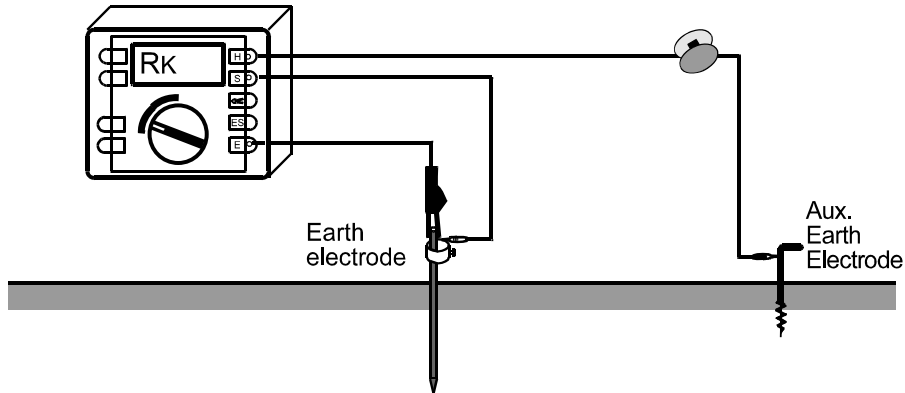

Turn central rotary switch to position "RE 3pole"
Wire instrument according to picture
Call display R_K with "DISPLAY" button
Implement compensation with "START" button

The compensation resistance is displayed only for as long as the "START" button is kept pressed. After releasing the "START" button the measured value is stored and the measuring instrument returns to the standard settings at the beginning of the measurement so that a succeeding measurement of the earthing resistance can be implemented by pressing "START" again. Thereafter, R_K is subtracted from the actual measured value.

If the compensation value has to be reset to the basic setting (0.000Ω), the compensation sequence has to be implemented with an open (disconnected) measuring lead or the central rotary switch one step.

8.5 Measurement of soil resistivity

The soil resistivity is the geological and physical quantity for calculation and design of earthing systems. The measuring procedure applied below uses the method developed by Wenner (F.Wenner, A method of measuring earth resistivity; Bull. National Bureau of Standards, Bulletin 12 (4), Paper 258, S 478-496; 1915/16).

Measuring process:

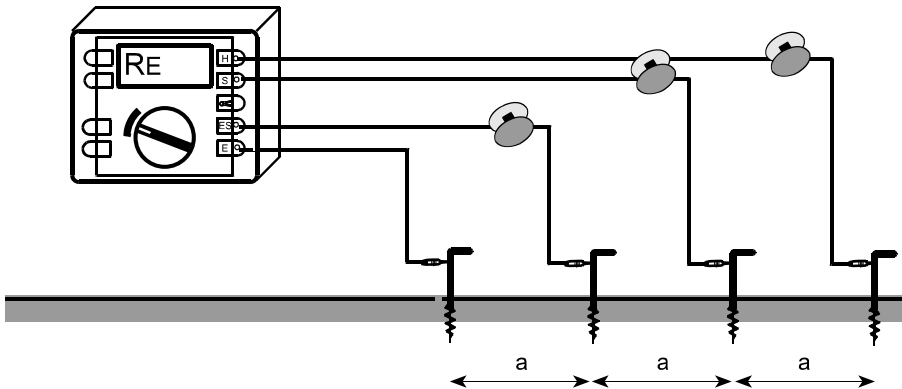

Four earth spikes of the same length are positioned into the soil in an even line and with the same distance "a" to each other. The earth spikes should not be hammered in deeper than a maximum of 1/3 of "a".

Turn central rotary switch to position "R_E 4pole"

The instrument is to be wired according to picture and notices given on the display.

A flashing of the sockets symbols E ES S H or V , points to an incorrect or incomplete connection of the measuring lead.

Push "START" button

Read out measured value R_E

From the indicated resistance value R_E, the soil resistivity calculates according to the equation :

$$\rho_E = 2 \pi \cdot a \cdot R_E$$

ρ_E mean value of soil resistivity ($\Omega \cdot m$)

R_E measured resistance (Ω)

a probe distance (m)

The measuring method according to Wenner determines the soil resistivity down to a depth of approx. the distance "a" between two earth spikes. By increasing "a", deeper strata can be measured and checked for homogeneity. By changing "a" several times, a profile can be measured from which a suitable earth electrode can be determined.

According to the depth to be measured, "a" is selected between 2 m and 30 m. This procedure results in curves depicted in the graph below.

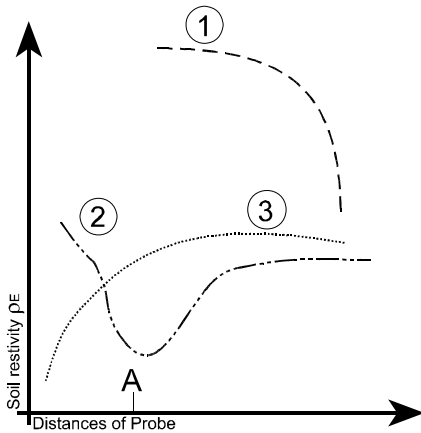

Curve 1: As ρ_E decreases only deeper down, a deep earth electrode is advisable

Curve 2: As ρ_E decreases only down to point A, an increase in the depth deeper than A does not improve the values.

Curve 3: With increasing depth ρ_E is not decreasing: a strip conductor electrode is advisable.

As measuring results are often distorted and corrupted by underground pieces of metal, underground aquifers etc, a second measurement, in which the spike axis is turned by an angle of 90° , is always advisable (see picture).

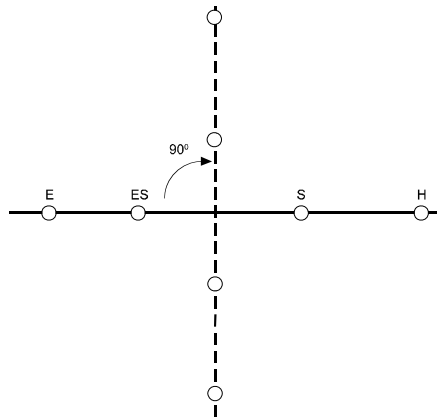

8.6 Measurement of resistances

8.6.1 Resistance measurement (R~)

This measuring function determines the ohmic resistance between 0.001Ω and $300 \text{ k}\Omega$. The measurement is done with AC voltage. For measurements of very low resistances a compensation of the connecting leads is suggested (see 8.6.3).

Measuring process:

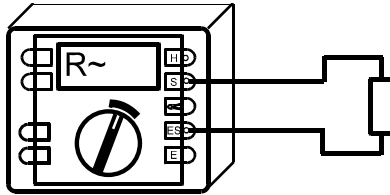

Turn central rotary switch to position "R~" .

Connect instrument according to picture

In this mode, all settings and LIMIT values available can be called with "DISPLAY" and the measuring frequency can be set .

Press " START " button

Read out measured value

8.6.2 Resistance measurement (R ∞)

In this measuring mode all resistances from 0.001 Ω to 3 k Ω can be measured with DC voltage and automatic polarity reversal as per VDE 0413/part 4

To achieve highest accuracy 4 pole measurements are possible. To balance the extension lead, a compensation has to be done.

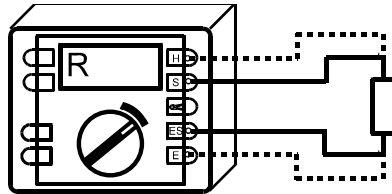

Connect instrument according to picture

Turn central rotary switch to position "R ∞ "

In this mode, all settings and LIMIT values available can be called with "DISPLAY".



WARNING: Before starting a measurement bring plant or test object in off circuit condition! With an external voltage higher than 3 V measurement will not be started.



WARNING: Due to the high measuring current inductive loads can cause lethal induced voltages during disconnection from the measuring circuit.

Start measurement with "START" button. First, "R₁" with positive voltage is measured on jack "E". After releasing the "START" button "R₂" is measured with negative voltage on jack "E". The respectively higher measured value is displayed first.

The second measured value can be called with "DISPLAY". If the set limit value (R LIMIT) is exceeded the limit can also be displayed.

Evaluation of measured value:

Taking into account the maximum operating error, the diagrams show the maximum admissible display values to be displayed so not to exceed the required resistance.

Measuring Range 29,99 ... 299,9 ... 2999 Ω

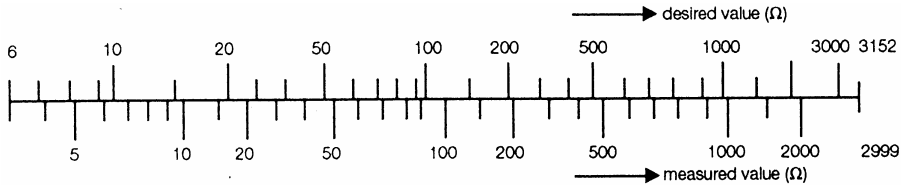

8.6.3 Compensation of measuring lead resistance

Call display of R_K with button "DISPLAY" .

Short circuit measuring lead according to picture.

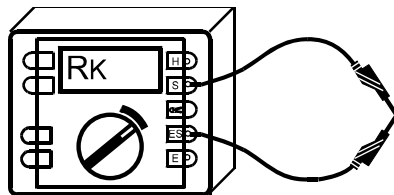

Press "START" button. Value R_K is stored after the release of the "START" button, the display jumps back to voltage measurement. Thereafter, R_K is subtracted from the actual measured value. Turning the central rotary switch for a short moment deletes the line compensation again.



8.7 Changing of all data settings with personalized CODE

With this function (F_M, U_M-Limit, Limit, beeper, ratio, R*, F*) limit- and set values can be programmed which keeps them memorized even if the instrument is switched ON/OFF. This feature enables the operator to create an instrument set-up with customer defined settings according to the specific need.

**Settings can only be made in the respective functions
(position of central rotatry switch)**

Function	Parameter	Setting range	Standard presetting
RE 3pole	F _M	(AFC/94/105/111/128)Hz	AFC
	U _M	48 V/20 V	48V
	R _K	0.000 Ω ... 29.99 Ω	0.000 Ω
	LIMIT	On / Off	Off
	R _E LIMIT	0.000 Ω ... 999 kΩ	999 kΩ
RE 4pole	♪ (Warning sound)	On/Off	Off
	R*	On/Off	Off
RE 3pole  and RE 4pole 	F _M	(AFC/94/105/111/128)Hz	AFC
	U _M	48 V/20 V	48V
	R _K	0.000 Ω ... 29.99 Ω	0.000 Ω
	I (ratio)	80 ... 1200	1000
	LIMIT	On/Off	Off
	R _E LIMIT	0.000 Ω ... 999 kΩ	999 kΩ
	♪ (Warning sound)	On/Off	Off
R~	F _M	(AFC/94/105/111/128)Hz	AFC
	R _K	0.000 Ω ... 29.99 Ω	0.000 Ω
	LIMIT	On/Off	Off
	R ~ LIMIT	0.000 Ω ... 999 kΩ	999 kΩ
	♪ (Warning sound)	On/Off	Off
R≡ 2pole and 4pole			
	R _K	0.000 Ω ... 29.99 Ω	0.000 Ω
	LIMIT	On/Off	Off
	R LIMIT	0.000 Ω ... 9,99 kΩ	9.99 kΩ
	♪ (Warning sound)	On/Off	Off

TO STORE A CODE

Press all 4 keys simultaneously and move central selector from OFF to the desired measuring mode.

The display shows "C _ _ _".

Now enter the CODE-number. Any three-digit number can be entered.

NOTE: Once a CODE has been entered, all subsequently programmed values can only be changed after entering the CODE number. Once a "CODE" has been entered, it cannot be erased or changed unless it is known. If an unknown "CODE" has been programmed, it can only be read or erased by its author or manufacturer. Therefore note down your personal "CODE" here.

CODE . . .

Inputing the code is done by means of the " CHANGE ▲ " and " SELECT ► " keys.

Pressing the "DISPLAY" key completes input.

The CODE is now stored, and the display shows " C ON ".

If the display " C ON" is acknowledged by pressing "DISPLAY", the first parameter of the selected measuring function is displayed and can be changed with the "CHANGE ▲ " and "SELECT ► "keys.

The changed value is stored by pressing the "DISPLAY" key.

Pressing the " START " key exits the setting program.

The new parameters are now used for measurements after each new power-up.



ATTENTION: If the limit values required by regulations are changed incorrect, erroneous test results may be displayed.

TO DELETE A CODE :

Press all 4 keys simultaneously and move central selector from OFF to any measuring mode.

The display shows " C _ _ _ ".

Now enter the existing CODE-number.





Inputing the code is done by means of the " CHANGE ▲ " and " SELECT ► " keys. Pressing the "DISPLAY" key completes input.

Display shows "C ON". In the " C ON " state the CODE function can be disabled by pressing the " CHANGE▲" key. The display then shows "C OFF".

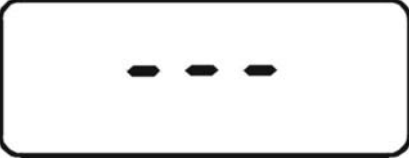
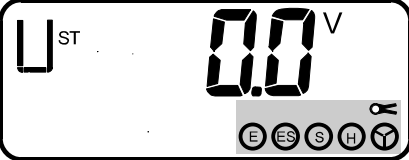

If this display is acknowledged by pressing the "DISPLAY" key, the user code and all changes of the limit values are erased. The original default values are restored into memory.

Now a new CODE-number may be programmed and used for setting new parameters.



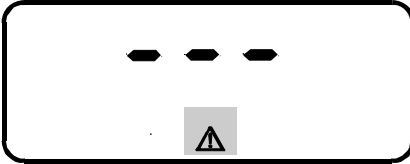
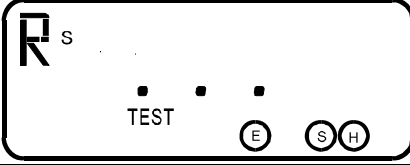
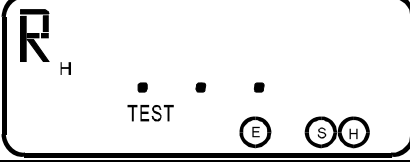
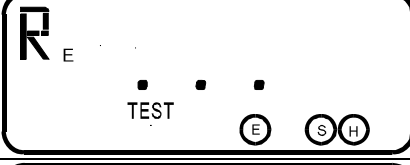
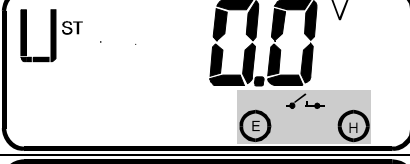
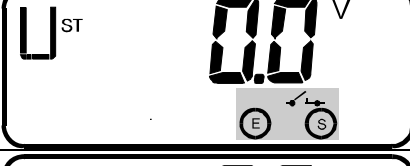

9 DESCRIPTION OF DISPLAYS

Function	Displays	Condition	Note
Before "START"		Stand by position to reduce power consumption	Turn rotary switch or push button. All measured values remain stored
		No or incorrect measuring lead connection	Apart from voltage measurement all measuring functions are locked!
		Battery voltage too low	Replace batteries!
		Beeper on	Acoustical warning if limit is exceeded
		Dangerous AC - voltage > 50 V	Apart from voltage measurement all measuring functions are locked!
		Interface operation active	Buttons are locked!

Legend :  = displayed flashing

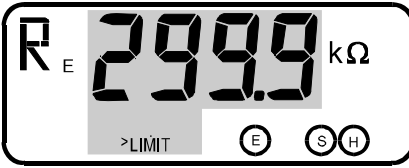
Function	Displays	Condition	Note
Before "START"		Rotary switch in intermediate position	Select correct position!
After "START"		Probe resistance is being tested	Wait for test result!
		Aux. current spike-resistance is being tested	Wait for test result!
		Earth resistance is being tested.	Wait for test result!
		Measuring circuit of earth- and auxil. earth electrode disconnected	Check lead connection on earth spikes measuring lead might be defective!
		Measuring circuit of earth- and probe electrode disconnected	Check lead connection on earth spikes measuring lead might be defective!
		Max allowable error exceeded because of too high sense or aux earth spike resistance	See graph on page 10; try to moisten soil or connect 2 nd aux earth spike in parallel

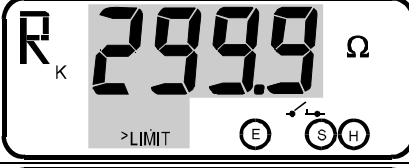
Legend :  = displayed flashing

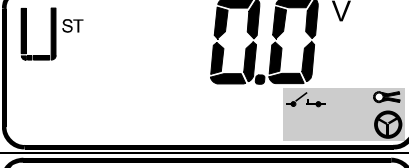
Function	Displays	Condition	Note
After "START"		Measuring range exceeded.	Measured value is higher than 300 kΩ.
		Display of measured value exceeds LIMIT.	Measured value is higher than set LIMIT.
		Compensation higher than measured value.	Delete compensation or switch instrument ON/OFF.
		Wrong polarity on jacks E and ES.	Reverse polarity.
		Measured value instable.	Unsteady noise voltage. Try time average measurement.
		Current in external transformer to low.	Reduce auxiliary current spike resistance.
	No reactions to button control etc.	Operation under faulty conditions.	Check batteries. Switch ON/OFF if still faulty, contact service.

Legend  = displayed flashing

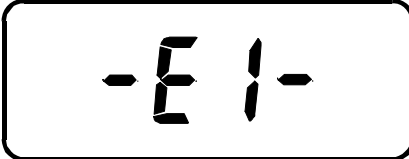
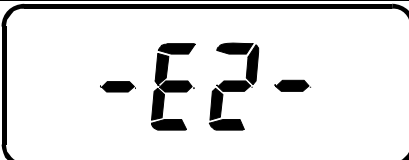
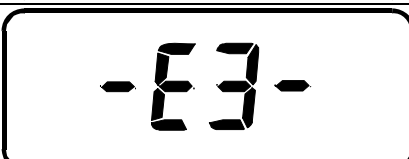
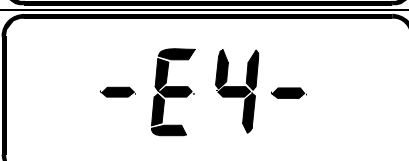
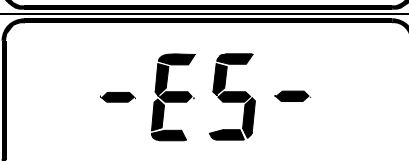
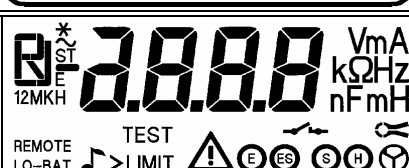
Function	Displays	Condition	Note
After "START"		Reverse orientation of current clamp or "upwards" current.	Reverse clamp or see note on page 28.
		Checksum of EE PROM incorrect.	Switch ON/OFF if still faulty; contact service.
		Hardware malfunction (e.g. current overload).	
		EE PROM memory access malfunction.	
		Internal computation malfunction.	
			Thermal overload.
		Battery voltage decreases at measurement.	The internal resistance of the batteries is too high (worn out, low temperature). Replace batteries, warm up instrument.

Legend  = displayed flashing

10 CARE AND MAINTENANCE

If used and treated properly, the instrument needs no maintenance. To clean the instrument, use only a moist cloth with some soap water or soft household detergent or spirit. Avoid aggressive cleaning agents and solvents (trilene, chlorothene etc.).

Service work must only be undertaken by trained qualified staff.

In all repair work care must be taken that the design parameters of the instrument are not modified to the detriment of safety, that assembled parts correspond to the original spares and that they are reassembled properly (factory state).



CAUTION! Before any maintenance, repair or parts replacement the instrument must be disconnected from all voltage sources.

10.1 Recharging NiCad batteries

Both versions can be retro-fitted with a rechargeable NiCad battery pack. Recharging of NiCad battery pack inside the instrument is possible with a special quick charge unit plus a mains adapter or an adapter cable for car cigarette lighter.



WARNING! Only use the above mentioned quick charge unit. Otherwise, no sufficient separation of potentials is guaranteed.

10.2 Replacing batteries

This instrument is equipped with six 1.5V batteries IEC RL 6. If after pressing the START-button all display-segments are lit (instrument resets, display-test) or if "LO-BAT" appears on display during a measurement the batteries must be replaced or the accumulators must be recharged.



CAUTION! For replacement of batteries the measuring cable must be disconnected, and the instrument switched off. Now the two screws at the rear of the instrument can be loosened with a suitable tool (screwdriver) and the battery recess cover removed.

When replacing batteries, mind the correct polarity.

Always replace the complete set of batteries.

Note: For protection of the environment, please ensure proper disposal of the batteries.

10.3 Recalibration

This instrument exceeds the prescribed accuracies by multiples as it leaves the factory. To maintain it in this state, we recommend a check at 3-year intervals. Please contact the nearest sales or service center for this purpose.

As an extra service feature we offer you periodic checking and calibration of your meters. You may order, for a fee, either company test certificates or test certificates of the public calibration service at your option. These orders will be carried out either generally or with additional test records (measuring points) as ordered by you.

10.4 Storage

If the instrument is stored or remains unused for some time, the batteries should be removed and stored separately to guard against damage by leaking electrolyte.

11 SERVICE

Dear Customer:

This high-grade instrument has been developed, designed and manufactured by specialists according to the latest technical aspects, taking into account the

DIN ISO 9001 Quality Assurance System.

If you should still have reason for a complaint, please contact our nearest service center, stating the reason for your **complaint in all detail and quoting the production number** and enclosing a copy of the invoice or delivery note.

NOTE: For reasons of clarity, these Instructions do not contain every detail concerning each type of the product, nor can it take into account every imaginable case of set up, operation or maintenance.

If you require further information or if special problems arise which are not covered in sufficient detail in the Operating Instructions, please ask our local agent for the required information.

Please note that the contents of these Instructions neither constitute part of nor modify any earlier or existing agreement, promise or contract. All obligations result from the pertinent contract of sale, which also contains the sole and comprehensive warranty regulations. These contractual warranty regulations are neither extended nor limited by compliance with these Operating Instructions.

11.1 WARRANTY

This product is warranted to be free from defects in material and workmanship for a period of 24 months from the date of shipment.

Correction shall be in the form of repair or replacement of the defective items or components, freight paid by the customer both ways. Such correction shall constitute a fulfilment of all LEM liabilities in respect to said items and components. In no event shall LEM be liable for consequential damage.

12 Basic APPENDIX

12.1 Earthing resistance

Per definition, the earthing resistance consists of several individual resistances.

- 1) The resistance of connecting lead to earth electrode
- 2) The resistance of the actual earth electrode; earthing rod, earthing plate, earthing strip, mesh earth electrode etc.
- 3) The dissipation resistance, the resistance between earth electrode and soil potential .

As the connecting cable and the resistance of the earth electrode are neglectably small after correct dimensioning, the earthing resistance dominantly depends on the dissipation resistance. This shows that an accurate measurement of the dissipation resistance is necessary to determine the exact earthing conditions for protective measures. As the dissipation resistance is not only dependent on the specific soil resistivity, that is the resistance of the actual soil (gravel, clay, granite), but also significantly depends on the shape of the earth electrode, a metrological check has to be made even if the position of the earth electrode and the condition of the soil is well known.

For redimensioning of an earthing system, e.g. a lightning protection, an approximate calculation, according to the table below, is possible. As a basis for this calculation the soil resistivity of the spot where the earth electrode is to be installed has to be known.

Type of soil	Soil resistivity [ρ_E]	Earthing resistance (Ω)					
		Earthing rod m depth			Earthing strip m		
	$\Omega.m$	3	6	10	5	10	20
Moist humus soil, moor soil, swamp	30	10	5	3	12	6	3
Farming soil, loamy and clay soils	100	33	17	10	40	20	10
Sandy clay soils	150	50	25	15	60	30	15
Moist sandy soil	300	66	33	20	80	40	20
Dry sandy soil	1000	330	165	100	400	200	100
Concrete 1 : 5*	400				160	80	40
Moist gravel	500	160	80	48	200	100	50
Dry gravel	1000	330	165	100	400	200	100
Stoney soil	30000	1000	500	300	1200	600	300
Rock	10^7	-	-	-	-	-	-

* for concrete mixtures 1 : 7 the values have to be increased by 24 %

12.2 Soil resistivity ρ_E

The soil resistivity is the resistance measured between two opposing surfaces of a cube of homogenous soil material with a lateral length of 1 meter. The unit is Ωm (see picture)

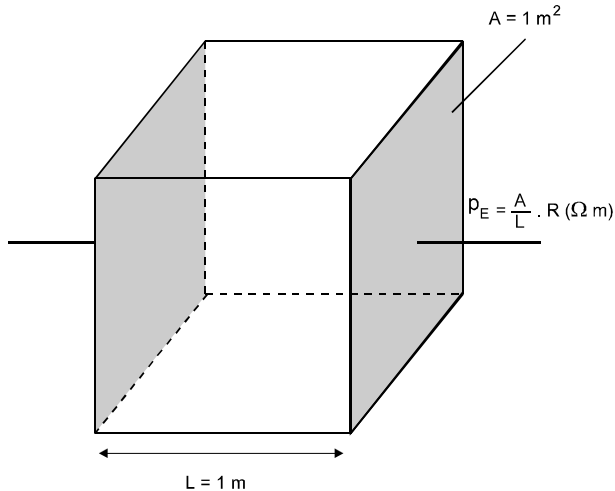

The soil resistivity significantly depends on the specific kind of material (farming soil, dry sand, moist sand, concrete, gravel etc.), but also depends on seasonal changes. Dry soil has a higher resistivity than moist soil and frozen ground has a higher resistivity than dry, warm sand (see picture).

The two examples below show the change of resistivity during the course of one year.

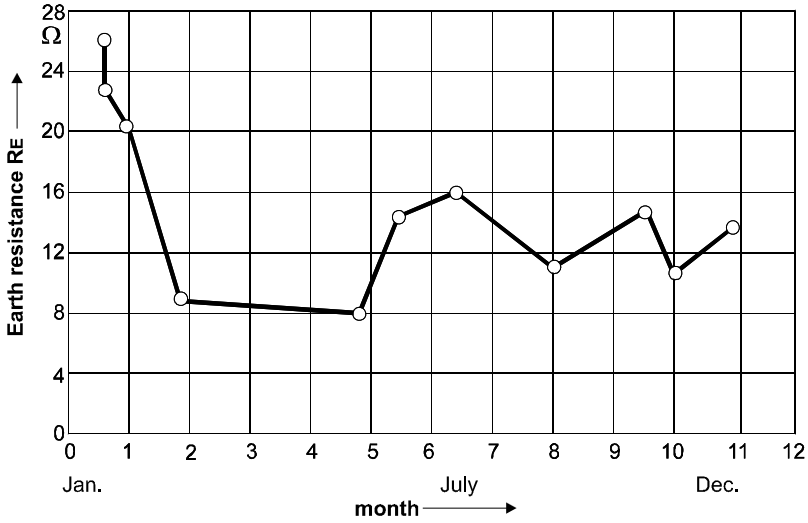

Temporal change of the earthing resistance of a conductor earth electrode (earth strip, earth cable).

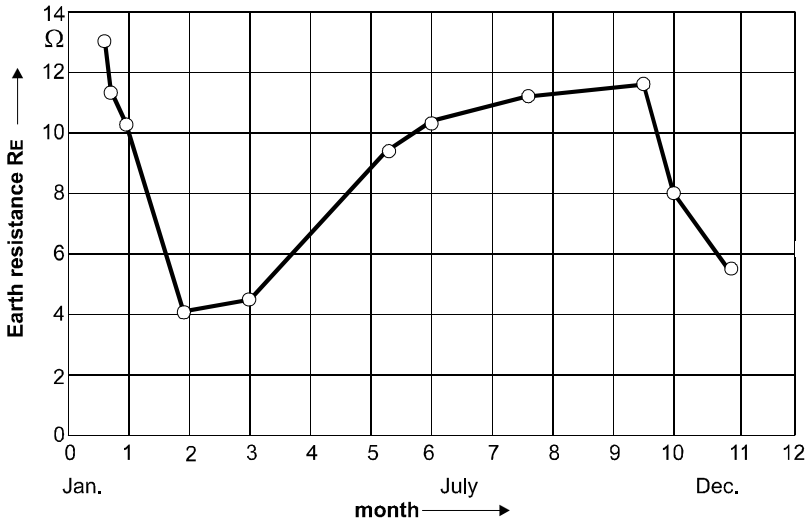

Temporal change of the earthing resistance of a buried earth electrode (earth pipe, earth plate)

12.3 Measuring method

The current voltage measuring method is based on the block diagram circuit shown in the figure below.

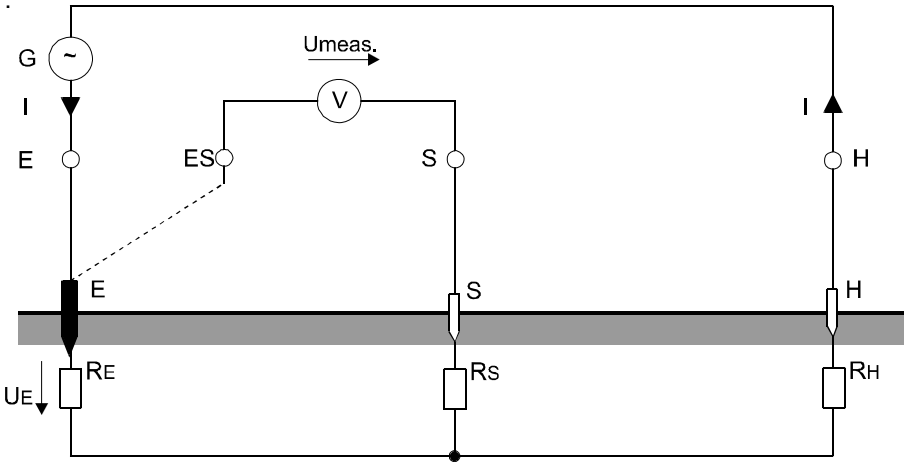

An AC generator G feeds current I via earth electrode E (earth electrode resistance R_E) and auxiliary earth electrode H (auxiliary earth electrode resistance R_H). Voltage U_E drops on earthing resistance R_E (U_E proportional to R_E). This voltage is picked off and measured by probe S . With the so called three wire circuit, the instrument sockets E and ES are connected to each other. In a four wire circuit an separate cable is used to connect socket ES with the earth electrode. With that, the voltage drop of the cable between socket E and earth electrode is not measured. As the voltage measuring circuit has such a high impedance, the influence by the probe resistance R_S is neglectable within certain limits. Thus the earthing resistance evolves

$$R_E = \frac{U_{Meas.}}{I}$$

and is independent from the resistance of the auxiliary earth electrode R_H . The generator runs at a frequency between 70 and 140 Hz.

It has to hold a minimum distance of 5 Hz to one of the nominal frequencies between 16 2/3, 50 or 60 Hz and their harmonic waves. A frequency selective filter adjusted to the generator frequency is inserted.

12.4 The potential gradient area

Around every earth electrode a so called potential gradient area develops during the flow of an electric current (see picture below).

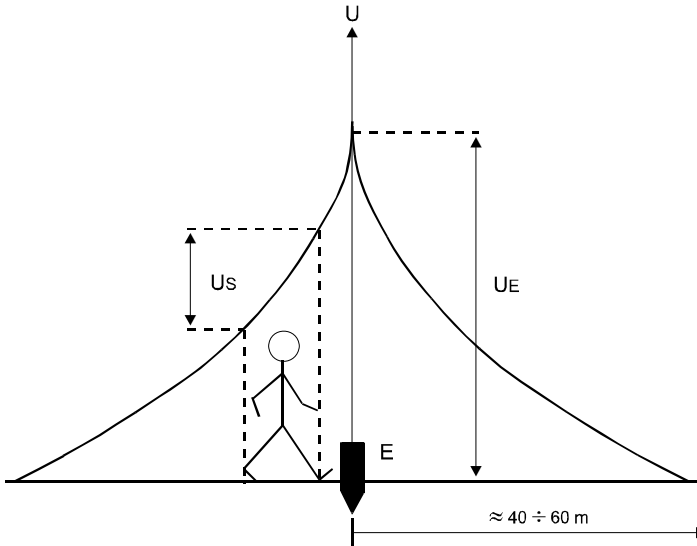

If then the voltage between the earth electrode and a probe with a distance "a" from the earth electrode is measured, the value increases less with increasing distance. If in the end the voltage does not change anymore, the probe is levelled to earth potential F_E so to say outside the potential gradient area.

It is the soil resistivity only that holds responsible for the diameter of the potential gradient area. This means the diameters in soils with a bad conductivity are correspondingly wide (30 ... 60 m), soils with a good conductivity correspondingly narrow (10 ... 15 m).

Determining the probe- and auxiliary earth electrode resistance provides information about the size of a possible potential gradient area. High resistances lead to correspondingly large gradient areas and vice versa. In this context it has to be taken into account that soils with a good conductivity and correspondingly small potential gradient areas result in a relatively steep voltage shape and therefore in a relatively high step voltage. If necessary, such systems have to undergo a potential check.

12.5 The influence of potential gradient areas on earth resistance measurement

To pick off the true voltage drop from the earthing resistance (= the resistance between the earth electrode and the soil potential F_E) it is to be assured that the probe is set outside the potential gradient area of all connected earth electrodes and the auxiliary earth electrode H.

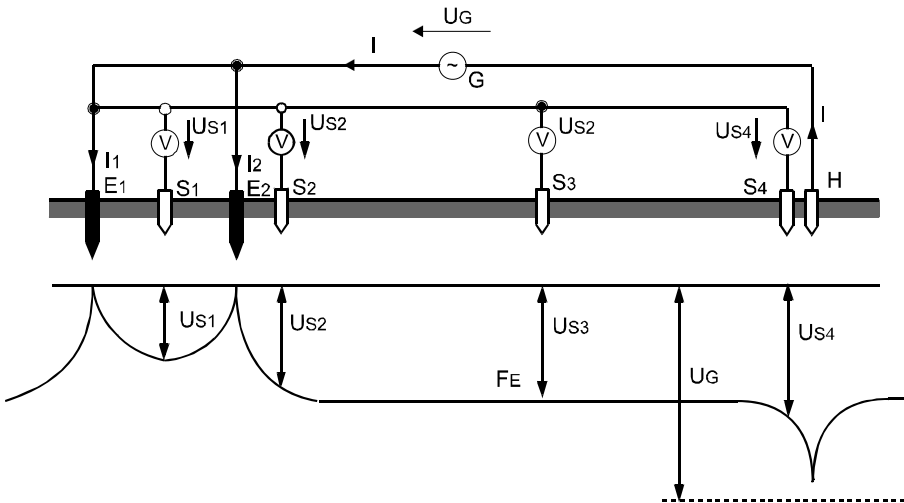

A probe positioned inside a potential gradient area leads to incorrect measuring results. As it can be seen in the picture above, probe voltages U_{S1} and U_{S2} of probes S_1 and S_2 deliver a value too low, which also means that the earthing resistance is too good (low resistance). Probe S_4 with U_{S4} on the other hand, picks up a value too high which points to worse (high resistance) earthing conditions. Only probe S_3 picks up the correct voltage between earth electrode and soil potential F_E .

For that reason it is advisable to repeat each measurement with repositioned probes and only to regard a measurement as successful and accurate if several subsequent measurements result in the same values.

Normally, a distance of 20 m to the earth electrode and to the probes to each other is sufficient.

12.6 Earth impedance (R^*) on high voltage transmission lines

The earthings of transmission line pylons are interconnected via the overhead earth wire.

This wire is not only ohmic. There is also inductivity and resistivity (L' , R'). For calculation of the short circuit current this impedance at line frequency has to be determined.

Inductivity and resistivity are known in most cases. Therefore the actual impedance can be calculated for each point of the line by a complex computation considering individual pylon resistance. This (computation) has to be done for each single pylon.

Now the earth impedance can be measured with this instrument!

The inductive portion of the impedance of the overhead wire is frequency dependent. Accordingly, the measuring frequency applied by the tester has to be close to the mains frequency in order to get correct readings.

For that reason ordinary testers using frequencies between 70 Hz and 140 Hz show incorrect readings. This instrument measures with 55 Hz to be near enough to 50 / 60 Hz line frequency but to avoid interference with them.

Notes:

LEM SUBSIDIARIES

AUSTRIA

LEM INSTRUMENTS

Tel: 02236 6910

Fax: 02236 62474

CHINA

BEIJING LEM

Tel: 10 804 90493

Fax: 10 804 90473

GERMANY

LEM DEUTSCHLAND

Tel: 06152 807650

Fax: 06152 807651

NETHERLANDS

LEM NEDERLAND

Tel: 0164 615462

Fax: 0164 616606

SWITZERLAND

LEM ELMES

Tel: 055 415 75 75

Fax: 055 415 75 55

USA

LEM INSTRUMENTS

Tel: 0310 373 0966

Fax: 0310 373 9056

BELGIUM

LEM BELGIUM

Tel: 067 550114

Fax: 067 550115

FRANCE

LEM FRANCE

Tel: 01 6918 1750

Fax: 01 6928 2429

JAPAN

NIPPON LEM

Tel: 06395 4073

Fax: 06395 4079

RUSSIA

TVELEM

Tel: 082 224 40 53

Fax: 095 230 22 60

UK

LEM UK

Tel: 0990 143803

Fax: 01695 50704

Printed in Austria / Gedruckt in Österreich / Imprimé en Autriche



LEM NORMA GmbH

Liebermannstrasse F01, CAMPUS 21

A-2345 Brunn am Gebirge

Tel: ++43(0)2236/691-0

Fax: ++43(0)2236/691-415

A 1885 51 GA 1 E

Right to change specification reserved /

Technische Änderungen vorbehalten /

Sous réserve de modifications

Distributor / Vertragshändler / Distributeur